

WS-400 & LS-400

SERIES 2.1

SETUP & ADJUSTMENTS

GRAVITY SPRAY GUN SMART GUIDE

a good start is halfway to success.

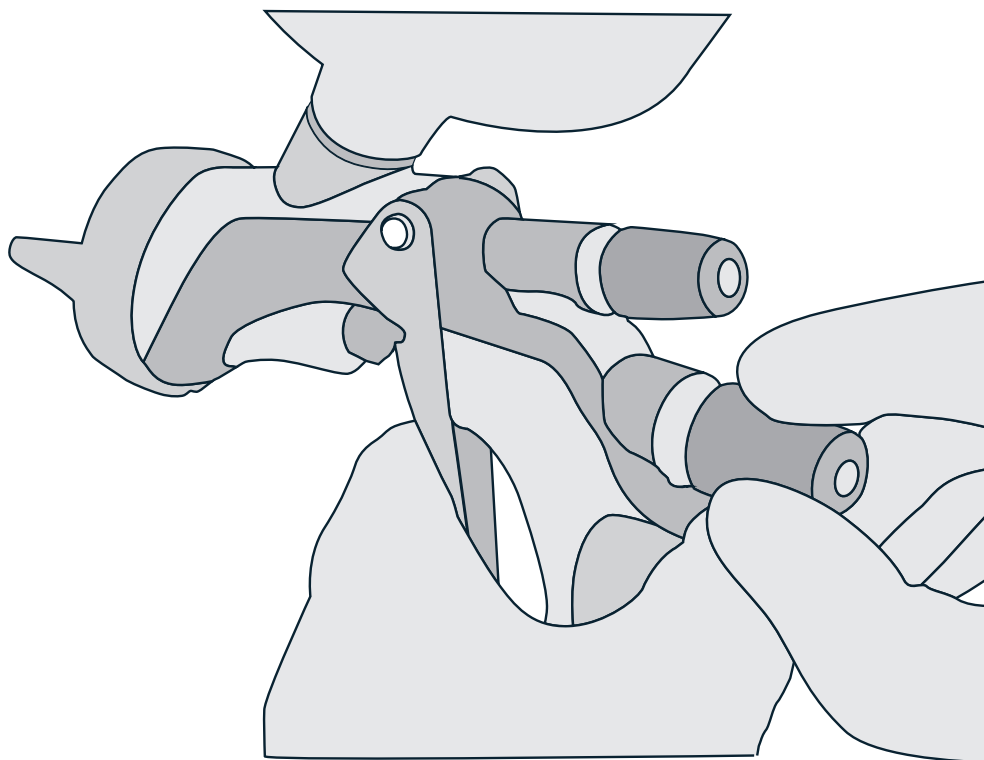

01. UNPACK

Unpack the spray gun and make sure that the product has not been damaged during transportation and that all the contents are included the packaging.

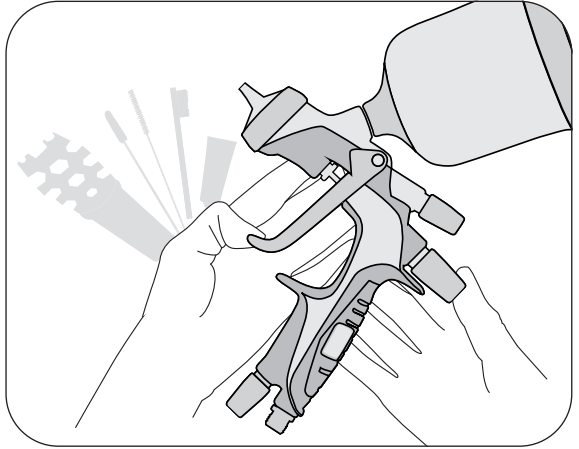

*Clean the fluid passages of the gun before the first use to remove any residue of oil. (*Refer to Cleaning Guide)

02. WEAR PROTECTIVE GEARS

IMPORTANT!

During all fases of setup and operation procedures, always wear proper body and re-spiratory protection such as: ANEST IWATA safety glasses, mask and gloves.

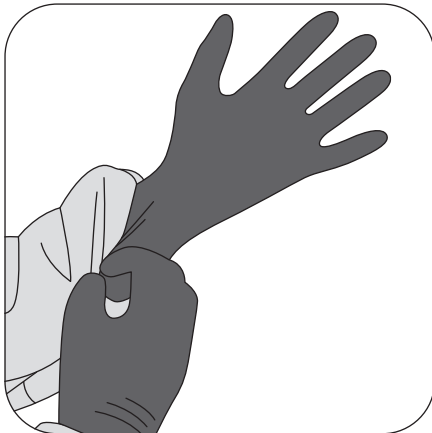

03. PRESSURE ADJUSTMENT - DIGITAL

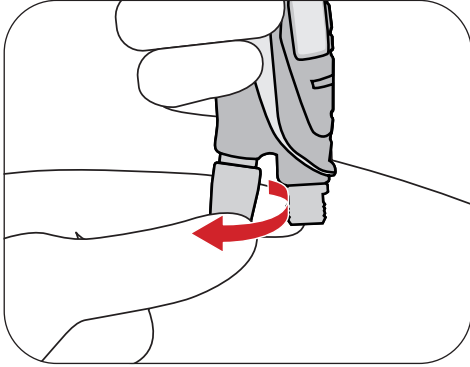

1 Turn the Air Adjustment Knob counter-clockwise to increase pressure.

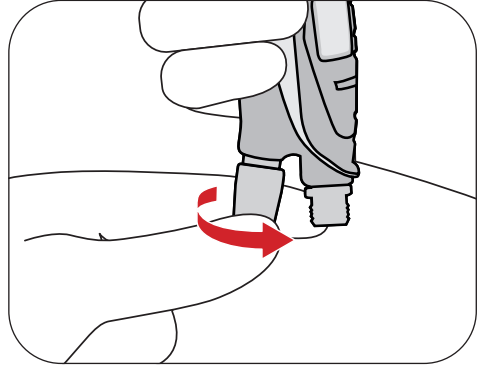

2 Turn Air Adjustment knob clockwise to decrease pressure.

04. DIGITAL PRESSURE GAUGE DISPLAY INFO

The digital pressure gauge display is available in 3 different pressure forms:

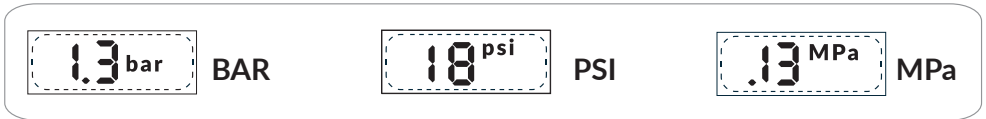

LIGHTING: At the time of purchase, the DPG-1 is in standby mode, waiting for input pressure. When the pressure exceeds 0.5 bar, the DPG-1 display activates and start indicating pressure. To adjust the outlet pressure open the Air Adjustment knob of the spray gun.



LOW PRESSURE INDICATION: If pressure becomes lower than 0.5 bar the display will indicate LO, it will switch off and enter in stand-by mode.

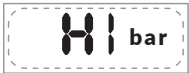

OVER-PRESSURE INDICATION: The maximum pressure limit is displayed on the screen as 10 Bar in the Bar version, and 97 psi in the psi version. When the measured values exceed these thresholds, the display will show the message HI and the device will automatically switch to stand-by mode.



LOW BATTERY: When battery charge becomes low, symbol appears on the display.



DISPLAY OFF: If the display is off, the causes may be:
- Pressure too low for a long time (below 0.5 bar)
- Pressure too high for a long time (above 9.9 bar/97 psi)
- Battery completely discharged

05. PRESSURE ADJUSTMENT - STANDARD

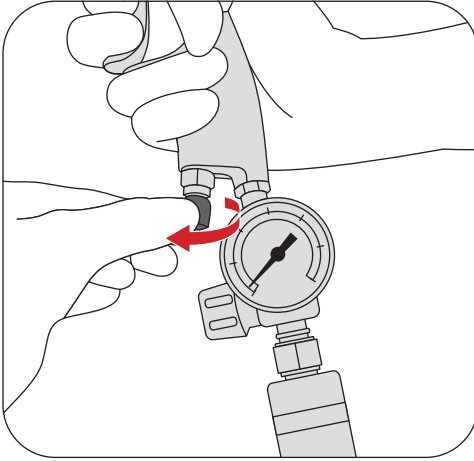

1 Fully open the Air Adjustment on the spray gun.

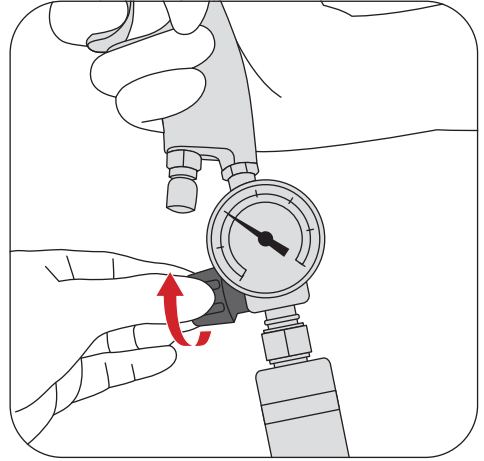

2 While pulling the trigger, use the Air Adjustment of the external pressure regulator to adjust the pressure.

06. PREPARE PAINT

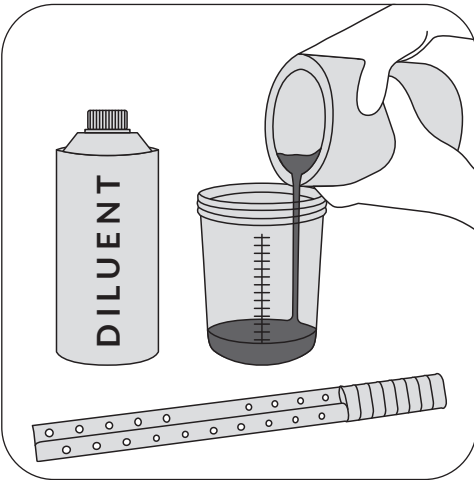

1 Prepare and dilute paint corresponding to paints TDS (technical data sheet).

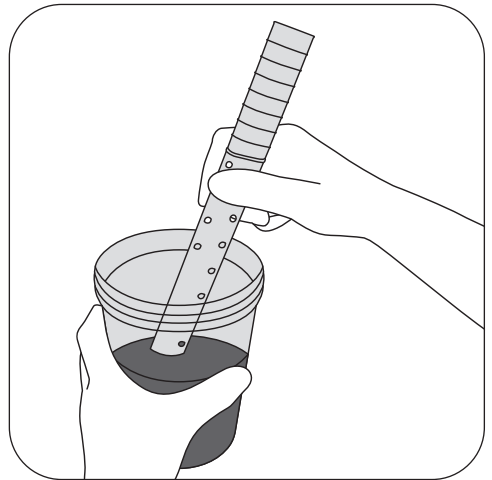

2 Make sure your paint is mixed before using it.

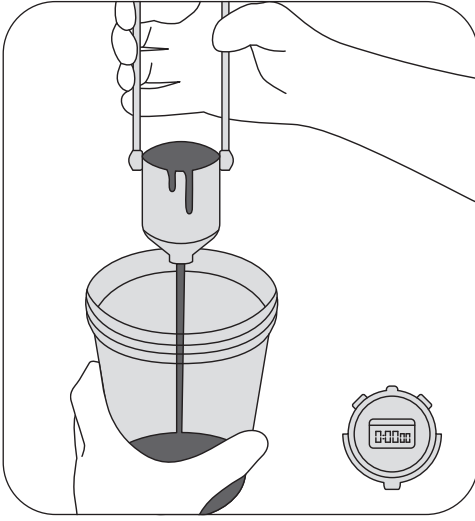

3 Check the correct viscosity of the paint as recommended by the paint manufacturer.

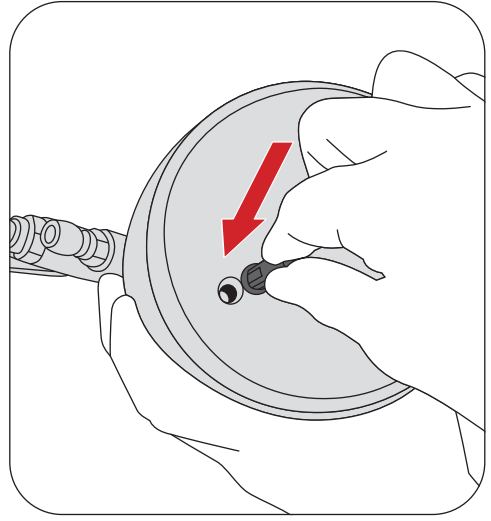

4 Fit the paint filter in the gravity cup.



5 Pour paint into the gravity cup by filtering it by an appropriate strainer to eliminate all impurities.

07. SETUP PRESSURE

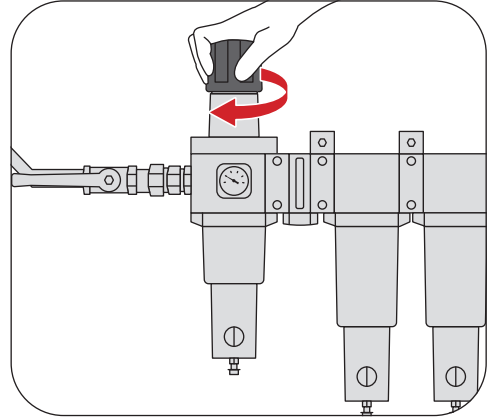
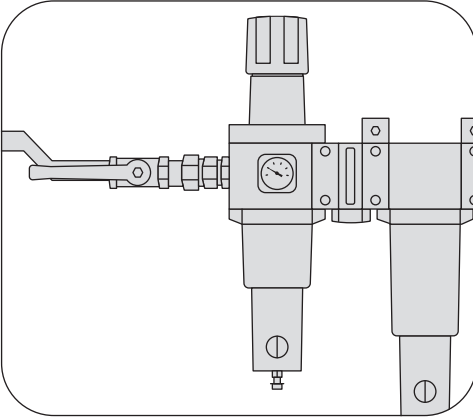

1 Check the functionality of the air filter unit.

2 Fully open the pressure regulator for the spray gun and set the correct air pressure on the gauge of the filter unit.

08. FLUID OUTPUT ADJUST

Use the fluid output adjustment to fine-tune fluid delivery, affecting trigger travel. For standard use, fully open the adjustment until the trigger contacts the gun body.

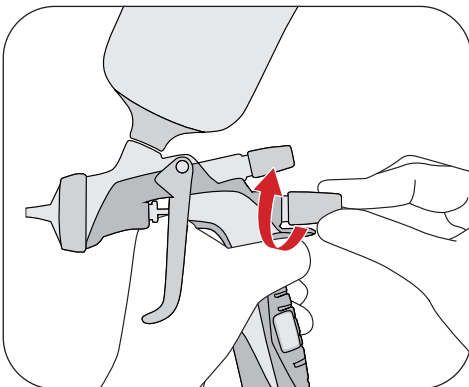

1 To decrease the fluid delivery, turn the fluid output adjustment knob clockwise.

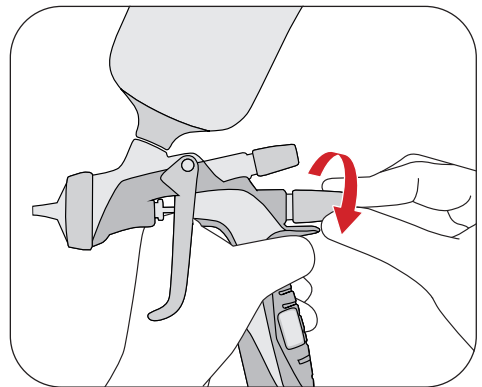

2 To increase the fluid delivery, turn the fluid output adjustment knob counter-clockwise.

09. PATTERN ADJUSTMENT

Use the fan pattern adjustment to either achieve a flat or a round fan pattern.

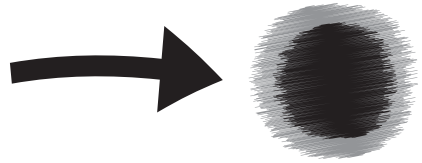
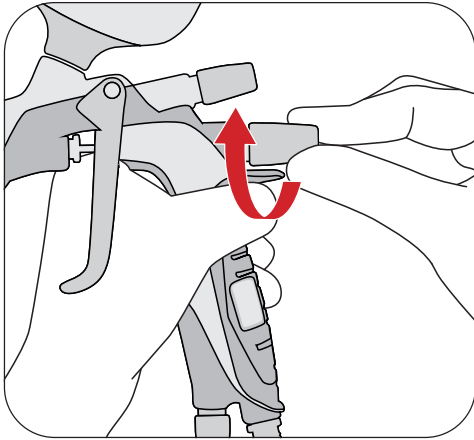

- 1** Turn the pattern adjustment knob clockwise to achieve a round fan pattern.

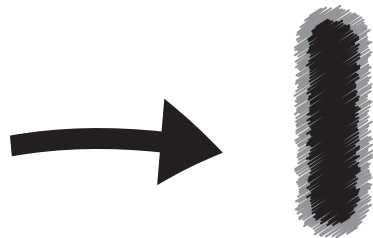
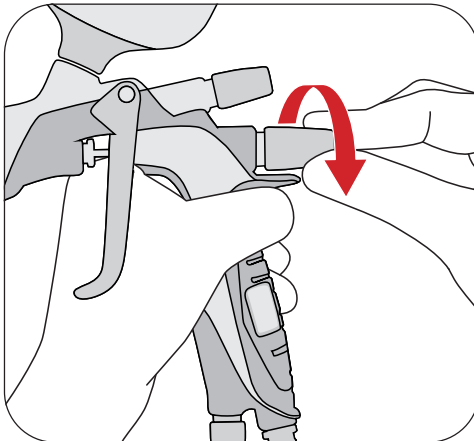

- 2** Turn the pattern adjustment knob counter-clockwise to achieve a flat & thin fan pattern.

TO AVOID A SPLIT FAN PATTERN

When working with a flat & thin fan pattern you can use the fan pattern adjustment to finetune it.

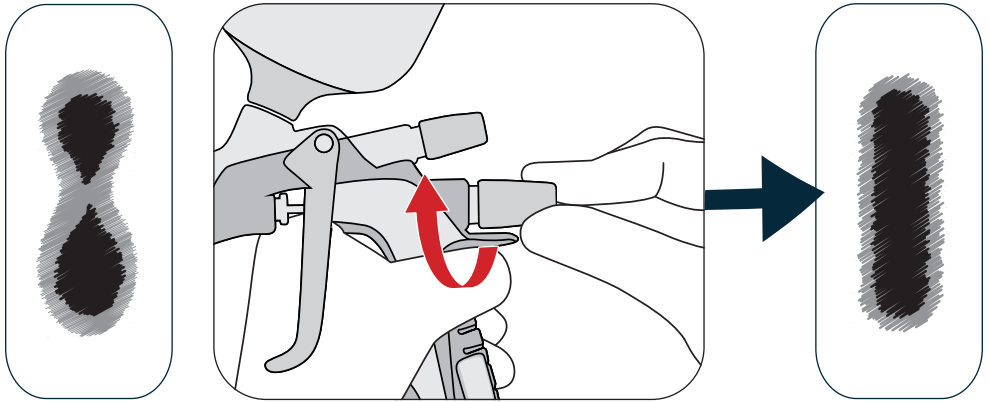

- 1** Turn the pattern adjustment knob clockwise.

TO AVOID AN OVAL FAN PATTERN

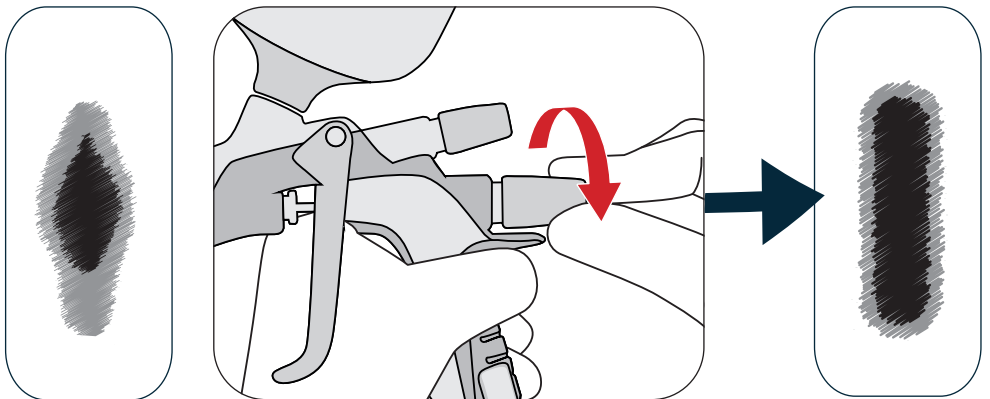

- 2** Turn the pattern adjustment knob counter-clockwise

10. TEST & SPRAY

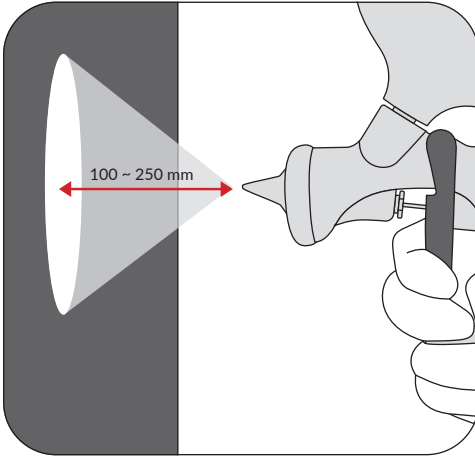

- 1** Set the spray distance from the gun to the workpiece, as near as possible within the range of 100 - 250 mm.

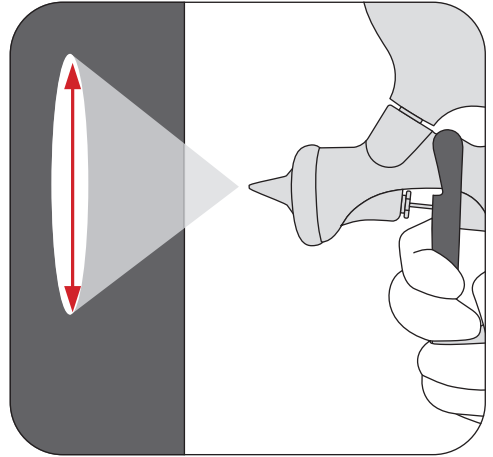

- 2** Test spray (proceed as recommended by the paint manufacturer).

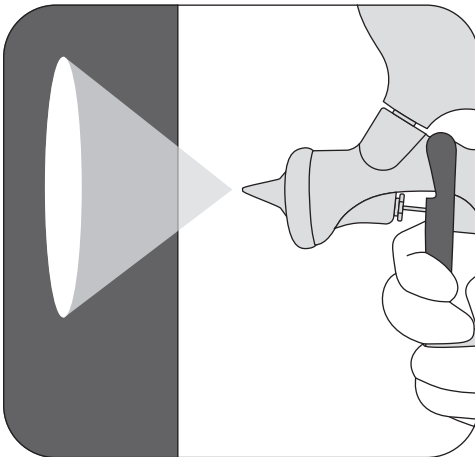

- 3** Proceed with the painting operations according to the manufacturer's instructions.

After spraying -> Cleaning the spray gun corresponding to the Cleaning Guide.

G R A V I T Y S P R A Y G U N S M A R T G U I D E



Get help with ANEST IWATA SUPPORT
www.anest-iwata-coating.com/support/

